

Astable operation  
 R4 = 10k  
 R6 = 30k  
 C9 = 10nF  
 Frequency of approx. 2.06KHz  
 Duty Cycle of 57.1%  
 ontime 277.2 uS  
 off time 207.8 uS

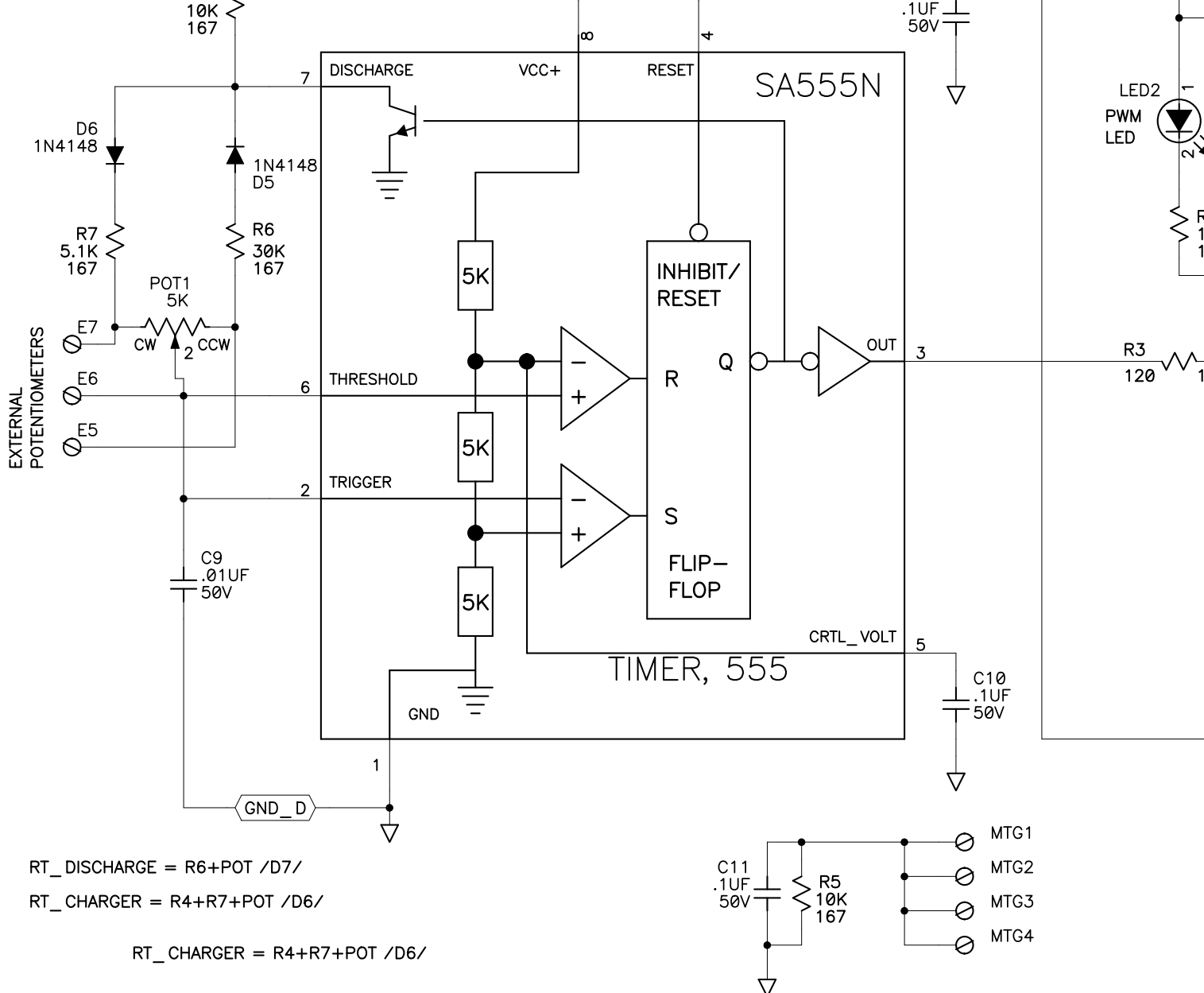

REVISIONS				
ECN	REV	DESCRIPTION	DATE	APPROVED
N/A	1.0	INITIAL RELEASE	07/06/07	TGP

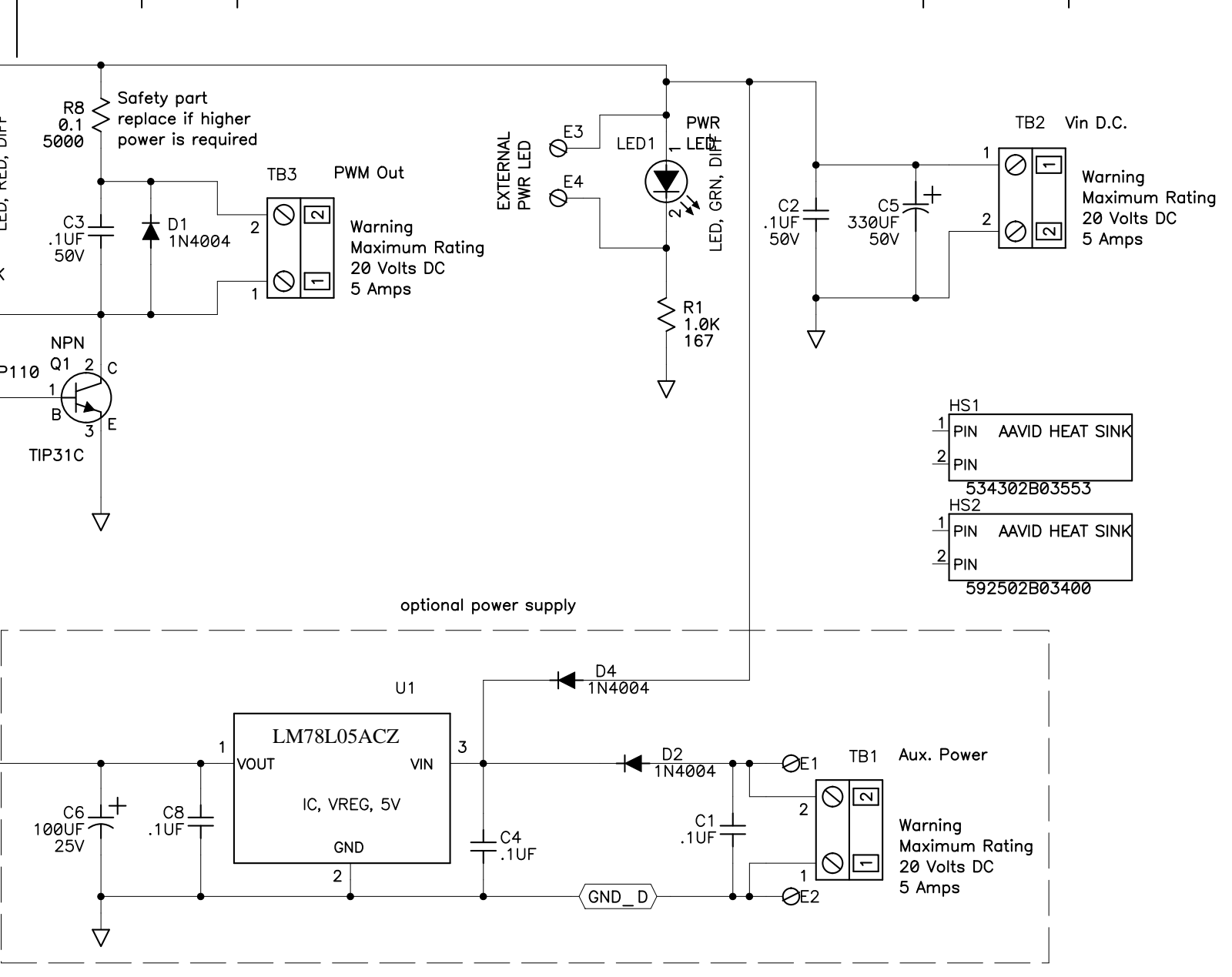

RT\_DISCHARGE = R6+POT /D7/  
 RT\_CHARGER = R4+R7+POT /D6/  
 RT\_CHARGER = R4+R7+POT /D6/

Danger statements are a description of an imminent hazards that will result in death or serious injury if not avoided and should be limited to the most extreme situations.  
 Danger: Description of imminently hazard and possible resulting injures

Warning statements are a description of a potentially hazardous situation which if not avoided could result in death or serious injury.  
 Warning: Description of hazard and possible resulting injures.

Caution statements are a description of a potentially hazardous situation which if not avoided could result in minor or moderate injury. It could also advise against unsafe practices  
 Caution: Description of hazard and possible resulting injures

ALL INFORMATION CONTAINED IN OR DISCLOSED BY THIS DOCUMENT IS CONSIDERED PROPRIETARY BY CADX SERVICES, INC. AND IS DELIVERED TO YOU IN CONFIDENCE. ALL DESIGN, MANUFACTURING, USE, PRODUCTION, AND ALL SALES RIGHTS, ARE EXPRESSLY PRESERVED BY AND TO CADX SERVICES, INC. AND COMMUNICATION OF THIS INFORMATION TO OTHERS IS PROHIBITED WITHOUT PRIOR WRITTEN CONSENT OF CADX SERVICES, INC.

DRAWN	CADX Services
CHECKED	N/A
ENG APVD	N/A
QA APVD	N/A
MFG APVD	N/A
DOC CONT	N/A
RELEASE	N/A

**CADX Services, Inc.** Tel: 585-624-1491 Fax: 585-582-1101  
 PO Box 311 Honeoye Falls, NY 14472 Web: www.cadx-pcb.com sales@cadx-pcb.com

**SCHEMATIC**  
**PWM, MOTOR DRIVE, 60W, 555, TH**

SCHMATIC	KS-PWM-60W-T-TH-0001	REV. 1.0	PCB	KF-PWM-60W-T-TH-0001	REV. 1.0
PRODUCT	KA-PWM-60W-T-TH-0001	REV. 1.0	GERBERS	KF-PWM-60W-T-TH-0001	REV. 1.0
SIZE	B	DWG NO.	KS-PWM-60W-T-TH-0001	REV	1.0
SCALE	NONE	DATE	Tue Oct 11, 2011	SHEET	1 of 1